

|

# STOP

## DON'T PANIC

### READ THE INSTRUCTIONS

**DIESELHEAT**  
**DH9 HYDRONIC KIT AND ASSEMBLED**  
**HOT WATER INSTALLATION MANUAL**  
Version 4 2023

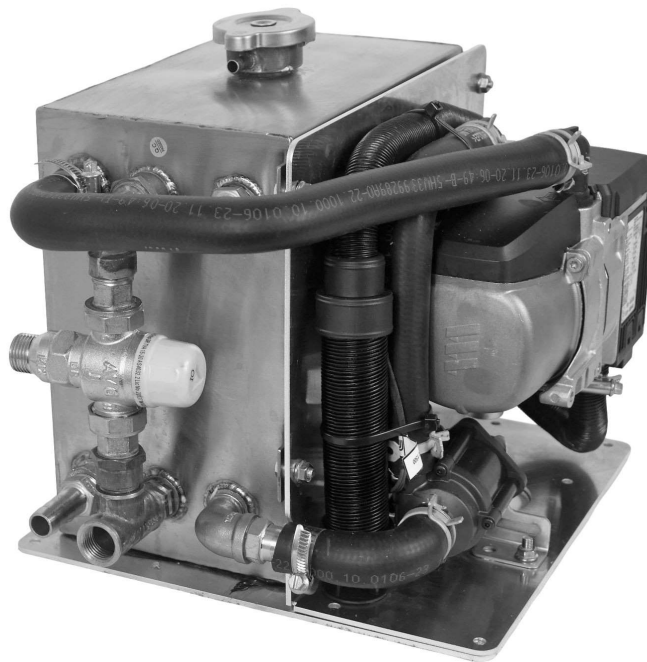

<b>Introduction - Principles of Operation</b>	<b>2</b>
Diesel Coolant Furnace	2
KIT - Component Location	2
KIT - Diesel Coolant Furnace Location Options	2
KIT - Hot Water Service Tank Locations	3
Important Considerations	3
Operating Considerations	4
<b>Set Up the Tank</b>	<b>5</b>
<b>Coolant Circulation Setup</b>	<b>5</b>
<b>Coolant Bypass Assemblies</b>	<b>9</b>
<b>Plumbing the Coolant Hoses</b>	<b>11</b>
<b>Coolant Circulation Pump</b>	<b>11</b>
<b>Coolant</b>	<b>12</b>
<b>Overflow Pipe</b>	<b>12</b>
<b>Fan Heater Installation</b>	<b>12</b>
<b>Controlling The Air Temperature</b>	<b>13</b>
<b>Tempering Valve - Controlling Water Temperature</b>	<b>14</b>
<b>Watermark Approval</b>	<b>15</b>
<b>Furnace Mounting (KIT)</b>	<b>15</b>
<b>Furnace Water Socket</b>	<b>15</b>
<b>Coolant Pump Orientation (KIT)</b>	<b>15</b>
<b>Fuel System</b>	<b>15</b>
Fuel Source	18
Allowable Suction Head	19
<b>Electrical Connection</b>	<b>19</b>
Main Wiring	20
Fuel Pump	20
Coolant Pump	20
Manual Control Wires	20
EasyStart Pro Controller Connector - DO NOT HIDE THIS	22
Diagnostic Port	22
Main Wiring Diagram	22
<b>Inlet and Exhaust General Arrangement</b>	<b>23</b>
<b>RV Exhaust</b>	<b>23</b>
<b>Marine Exhaust</b>	<b>26</b>
<b>Combustion Air</b>	<b>27</b>
<b>Commissioning</b>	<b>28</b>
Coolant Pump Priming	28
Initial Startup	29
Post Initial Startup	29
Coolant Furnace Operation	29
<b>Commissioning Troubleshooting</b>	<b>31</b>
<b>TWO YEAR PRODUCT WARRANTY</b>	<b>32</b>

## Installation Guidelines

Dieselheat is providing this installation manual to help make sure your installation is successful. Please read this guide carefully as many product issues can result from improperly performed installations. Performance loss, product damage or failure can result from poor installation practices or a failure to follow recommended guidelines.

We pride ourselves on our clients' successful installation and use of their new diesel hot water system. If you have any further questions after reading this manual, please give us a call.

This manual contains all the information required to set up the DH9 from KIT or ASSEMBLED for both Marine or RV. Note that for ASSEMBLED units, some sections of this manual are redundant as the tank plumbing will already have been completed.

This manual contains relevant extracts from the Eberspacher D5E Technical Manual, however it is not the complete manual. For the full manual please refer to the QR code opposite.



## Introduction - Principles of Operation

DH9 hydronic hot water heaters operate by transferring the energy from coolant heated by the diesel furnace to heat exchangers. The primary heat exchanger is the domestic water plate heat exchanger installed inside the DH9 tank. An additional, optional cabin fan heater (air heater) can also be used.

### Diesel Coolant Furnace

The diesel coolant furnace is the heart of the system. It is the component that burns the diesel/air mixture to generate heat. The heat is transferred to the coolant, which passes through the water jacket surrounding the furnace.

Hot coolant is circulated via the pump which is supplied with the furnace.

### KIT - Component Location

The DH9 KIT is designed to have the tank and furnace mounted independently, so it

is shipped as a kit for assembly by the installer.

The furnace can be located up to 4m from the hot water service tank, and as the furnace is IP rated it can be installed under the floor of a vehicle. However, we always suggest splash and stone protection be installed.

When remote-mounting the furnace, the coolant hoses can be insulated if the vehicle/boat is in an cold climate, but this is not necessary in most Australian conditions.

### External/Remote mounting:

- Increases the volume of coolant in the system, which is beneficial.
- Facilitates installation in tight spaces.

- Moves the furnace to a location where noise can be better managed.
- For marine installations, enables the furnace to be moved to a location where the exhaust is easier to install.

When remote-mounting the furnace:

- Take appropriate precautions to prevent external hose damage where hoses pass through walls or bulkheads.
- If the hoses need to be routed around corners or bends and there is a possibility of kinking, fit elbows into the hose.
- Always provide mechanical protection from stones, etc.
- Always protect from excess dust ingress.

#### KIT - Diesel Coolant Furnace Location Options

##### Caravan/RV

- On the right of the hot water service tank - this gives the most compact install with the components close together.
- Externally in a box (which must be ventilated when the furnace is running).
- Under the chassis on a vehicle. This is a good option because it means there will be no fuel line or exhaust connections in the vehicle, and noise will be reduced in the vehicle.

##### Marine

- On the right of the hot water service tank - this gives the most compact install with the components close together.
- Separated from the tank in the engine room.

- Separated from the tank in a locker/lazarette, which can facilitate easier installation of the marine exhaust system.

**Note: The diesel furnace should be installed below the middle of the hot water service tank to ensure it fills with coolant.**

**Note: The coolant circulating pump must be level with the tank connection point or below it.**

**Note: All diesel furnaces require servicing from time to time, so the installation location should always facilitate easy removal of the furnace.**

#### KIT - Hot Water Service Tank Locations

In most situations, the hot water service tank is mounted in the same compartment where a typical hot water service would be fitted.

For marine installations, the hot water service tank can be located in the engine room, under a seat in the cabin, or in the engine compartment.

**Ideally, the hot water service tank should be the highest point in the system. If this is not possible, a separate header tank may be required.**

**Do not hang the tank on its securing tabs. It must be supported from underneath.**

#### Hot Water Service Tank Mounting Requirements:

- Must be mounted vertically with filler cap on top.

- Filler cap should be accessible to fill the system and periodically check coolant level.

### Important Considerations

- No diesel appliances like ingesting dust. Consider air inlet locations and system location to minimise or prevent dust being sucked into the combustion inlet.
- Never combine exhausts, i.e. join exhausts from different devices.
- Keep fuel supplies and fuel plumbing as simple as possible to minimise the chance of air leaks. Always use the provided fuel line; never use a substitute.
- Always place furnace units where they can be easily accessed for service or removal.
- Avoid main power isolation switches - these will allow a user to cut power to a unit whilst it is running, bypassing the proper shut down /cool down process. This will damage the unit.
- Ensure adequate supply of combustion air. If locating the unit in a sealed box, the door must be open for the unit to run, or alternatively an air inlet pathway must be provided. Operating the unit with inadequate inlet air will cause sooting up and almost immediate need for service.
- For marine installations, when deciding where to locate the furnace, always take into account that the maximum allowable length of the exhaust is 2m.

### Operating Considerations

- Generally, units are designed to be switched on when needed and turned off when not in use. Extended periods with the unit left in standby are not recommended.
- Never store fuel in clear fuel tanks exposed to sunlight. This will cause fuel degradation or algae growth that can clog the fuel pump.
- Try to start showers when the furnace is running, not in standby, as the furnace restart time can reduce the amount of available hot water.





### Special Notes

**Do not connect power to the furnace until the installation is 100% complete.**

**If you need to get system error codes, remove a furnace lock, or run diagnostics, you will require an EasyStart Pro controller.**

**Never start the furnace without coolant in the system.**

### Options For DH Hydronic System Controls

Controller	Capability
 <p>Dieselheat Thermostat</p>	<p><b>This is the recommended setup. Note, no Eberspacher system diagnostics available.</b></p> <p>Can Do</p> <ul style="list-style-type: none"> <li>• Room temp control via auto fan speed control</li> <li>• 3 Speed manual fan control (Kalori or Dieselheat fans)</li> <li>• Eberspacher furnace on/off via start signal</li> </ul> <p>Cannot Do</p> <ul style="list-style-type: none"> <li>• Eberspacher hydronic furnace diagnostics</li> </ul>
 <p>Eberspacher EasyStart Pro</p>	<p>Can Do</p> <ul style="list-style-type: none"> <li>• Eberspacher hydronic furnace diagnostics</li> <li>• Furnace on/off via digital communication</li> </ul> <p>Cannot Do</p> <ul style="list-style-type: none"> <li>• Room temp control</li> <li>• Fan speed control</li> </ul>
	<p>If using both controllers, set up functions as follows:</p> <p>Dieselheat Thermostat</p> <ul style="list-style-type: none"> <li>• Room temp control via auto fan speed control</li> <li>• 3 speed manual fan control (Kalori or Dieselheat fans)</li> <li>• <b>DO NOT</b> connect furnace on/off via start signal as this will conflict with the Eberspacher controller.</li> </ul> <p>Eberspacher EasyStart Pro</p> <ul style="list-style-type: none"> <li>• Eberspacher hydronic furnace diagnostics</li> <li>• Furnace on/off via digital communication</li> </ul>
	<p>The Eberspacher furnace and Kalori fan heating heads can also be switched on/off with a toggle switch.</p> <p>Can Do</p> <ul style="list-style-type: none"> <li>• Eberspacher furnace on/off via start signal</li> <li>• 2 Speed manual fan control</li> </ul> <p>Cannot Do</p> <ul style="list-style-type: none"> <li>• Room temp control via auto fan speed control</li> <li>• 3 speed manual fan control</li> <li>• Eberspacher hydronic furnace diagnostics</li> <li>• Furnace on/off via digital communication</li> </ul>

## Set Up the Tank

The tank is shipped with the tempering valve installed and these connections are pressure tested prior to shipping.



We do not recommend moving or adjusting the tempering valve as the connections require special sealant and tightening.

For the KIT, 20mm hose tails are provided for the coolant inlet and outlet.

All connections on the tank for coolant need to be sealed with either thread tape or Loxeal 58-11 to ensure there are no coolant leaks.

## Coolant Circulation Setup

The system contains a coolant bypass hole inside the  $\frac{3}{4}$  connector (position 4) on the tank. This hole allows coolant to exit the plate heat exchanger and return to the tank without the need for external plumbing.

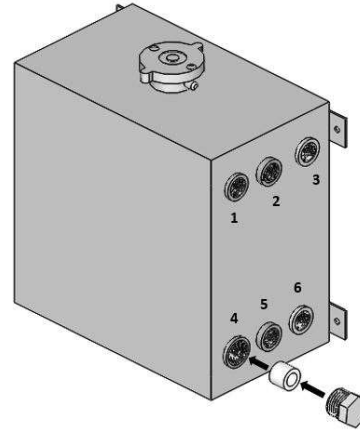

This hole can be blocked by inserting a bypass hole blocking ring into the  $\frac{3}{4}$  fitting prior to installing a hose tail.

### Connection Ports

1. Coolant in from furnace
2. Hot water out
3. Coolant return (from optional air heating) or plug.
4. Coolant out (to optional air heating) or plug.
5. Cold water in
6. Coolant out to pump inlet

**It is important to configure the tank properly to ensure good performance. Use the following scenarios to configure your tank.**

**Case 1: Hot water only installations.**

For hot water only installations, connectors 3 and 4 should be blocked with the supplied plugs. However, the bypass hole blocking ring should not be installed.

**Case 2: Installations with 1 fan head located within 1.5m of the hot water system and less than 0.5m above the top of the coolant tank.**

Ports 1 and 5 should have hose tails installed and the fan head should connect to those hose tails. **The bypass hole blocking ring should not be installed.** Coolant will flow to the fan head, but if the fan head circuit is turned off, coolant will bypass via the internal bypass hole.

This case also covers the use of the electric ball valve which is controlled by the Dieselheat Thermostat. The ball valve can be located in any position in the coolant circuit and will automatically shut down coolant circulation when the air heating fan is not switched on.



DH9 SCHEMATIC SETUP:  
FAN HEAD < 0.5M ABOVE TANK – INTERNAL BYPASS

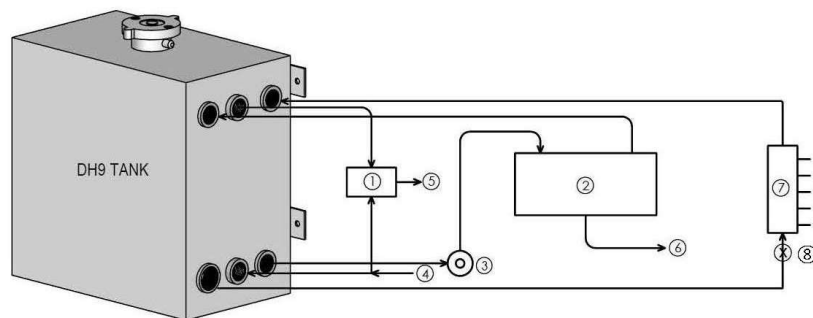

1. MIXING VALVE
2. HYDRONIC FURNACE
3. COOLANT PUMP COLD WATER SUPPLY
4. HOT WATER OUTLET
5. OPTIONAL FAN HEATING HEAD
6. EXHAUST
7. OPTIONAL FAN HEATING HEAD
8. OPTIONAL SHUTOFF VALVE



**Case 3: Installations with multiple fan heads, fan heads located more than 0.5m above the level of the tank or where the fan head is more than 1.5m from the tank - manual bypass valves.**

For these installations, ports 1 and 5 should have hose tails installed and the **bypass hole blocking ring must be installed**. This prevents coolant passing back into the tank and significantly increases the available pump pressure to drive circulation of the coolant.

DH9 SCHEMATIC SETUP:  
FAN HEAD > 0.5m ABOVE TANK - EXTERNAL BYPASS

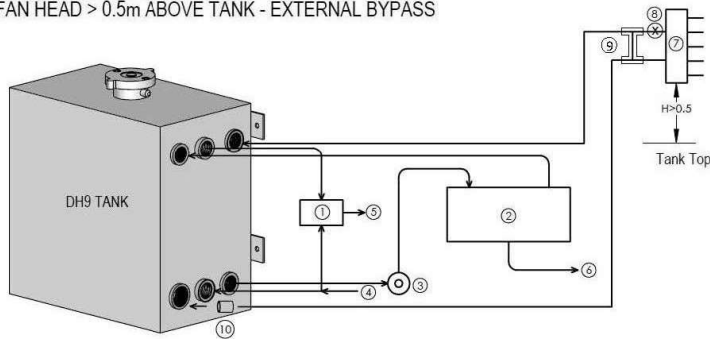

1. MIXING VALVE
2. HYDRONIC FURNACE
3. COOLANT PUMP
4. COLD WATER SUPPLY
5. HOT WATER OUTLET
6. EXHAUST
7. OPTIONAL FAN HEATING HEAD
8. OPTIONAL SHUTOFF VALVE
9. EXTERNAL BYPASS VALVE
10. BYPASS HOLE BLOCKING RING

DH9 SCHEMATIC SETUP:  
MULTIPLE FAN HEADS

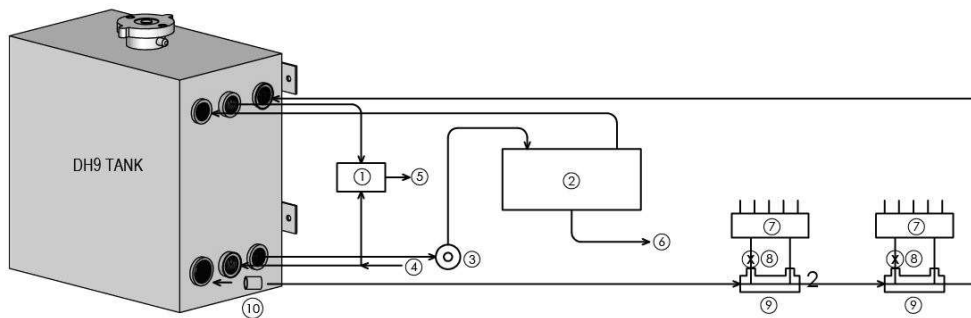

1. MIXING VALVE
2. HYDRONIC FURNACE
3. COOLANT PUMP
4. COLD WATER SUPPLY
5. HOT WATER OUTLET
6. EXHAUST
7. OPTIONAL FAN HEATING HEAD
8. OPTIONAL SHUTOFF VALVE
9. EXTERNAL BYPASS VALVE
10. BYPASS HOLE BLOCKING RING

**Case 4: Installations with multiple fan heads, fan heads located more than 0.5m above the level of the tank or where the fan head is more than 1.5m from the tank - 3 way electric ball valve.**

Ports 1 and 5 should have hose tails installed and **the bypass hole blocking ring must be installed**. This prevents coolant passing back into the tank and significantly increases the available pump pressure to drive circulation of the coolant.

The 3-way ball valve can then be used to automatically send all coolant to one or more fan heads when the air heating is on, or to recirculate all coolant back to the hot water system; bypassing the fan heads when air heating is off.

In this case, the electric ball valve is controlled by the Dieselheat Thermostat and must be located close to the hot water system so that the air heating coolant pipes do not get hot when air heating is not required.



**The orientation of the 3-way valve is important. Be sure to point the arrow on the sticker on the valve towards the hot water system.**

**Note: If you are unsure how to configure your tank or have doubts, please contact Dieselheat.**

## Coolant Bypass Assemblies

These coolant bypass assemblies are relevant to larger multi fan head systems or systems not using electrically operated coolant valves.

Coolant bypass assemblies must be installed on each fan head so that if the coolant is shutoff in any one fan head, coolant circulation is not stopped in the whole system.

For simple systems with 1 fan head where a bypass assembly can be mounted behind the fan head, a valveless bypass assembly can be used.



Because valveless bypass assemblies rely on the momentum of the coolant to force it through the fan head, it is important to install the bypass valve behind the fan head at approximately the same level as the fan head. This will allow an adequate flow of coolant through the fan head.



For larger systems or when a valveless bypass assembly cannot be installed at the same level as the fan head, a valved bypass assembly can be used.

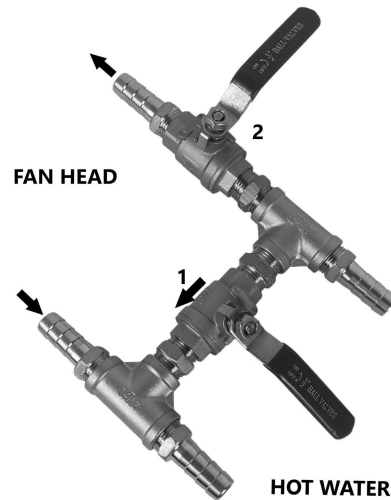

The valved assembly allows the bypass valve (1) to be partially shut, forcing coolant through the fan head but also allowing sufficient coolant to continue to flow through the system if the fan head shutoff valve (2) is closed.



**Note: If you are unsure of how to configure your air heating or have doubts, please contact Dieselheat.**

## Plumbing the Coolant Hoses

The hot water service to fan heating head plumbing should be done with 16mm ID rubber hoses and secured with hose clamps. Fan head installation kits from Dieselheat contain 2m of the necessary hose and all other hose tails and clamps.

If remote-mounting the furnace, the furnace to hot water service tank plumbing should be done with rubber or silicone hoses of 18-20mm ID and secured with quality hose clamps. The hose and clamps provided in the diesel furnace kits are designed for this purpose and should be utilised whenever possible.

## Coolant Circulation Pump

The coolant circulation pump supplied as part of the furnace kit will support systems with up to approximately 20m of coolant pipe.

Larger systems, particularly on boats, will require a booster pump. This can be powered and switched via a relay that can be attached to the Eberspacher D5E wiring loom.

## Coolant

The system must be filled with good quality engine coolant to ensure corrosion of internal components in the furnace is prevented.

Generally, commonly available coolants that include corrosion inhibitors are acceptable and should be used in accordance with the manufacturer's specifications.

Antifreeze is not required unless the system will be operated or stored in freezing conditions.

It is acceptable to initially leak test the system using water during the installation and testing phase, as long as the water is immediately removed and replaced with coolant.

**Note: Never leave a system that was filled with water for testing sitting empty, as residual moisture and air will immediately trigger internal corrosion.**

## Overflow Pipe

The DH9 tank runs at atmospheric pressure with the cap containing a small pressure relief vent hole. In almost all situations coolant will not overflow from the tank. It is suggested to install the overflow pipe through the floor or into the bilge in case small amounts of coolant overflow if the tank is overfilled or very rough conditions cause small overflows.

## Fan Heater Installation

The hoses connecting the cabin fan heater are connected directly to the DH9 tank ports. The cabin fan heaters should be plumbed with 16mm hose for short runs (less than 2m) or 16mm insulated PEX for longer runs.

If the components are located in separate compartments, drill two suitably sized holes through the flooring or walls to let the heater hose through. Take appropriate precautions to stop external hose damage when hoses pass through walls or bulkheads.

If the hoses need to be routed around corners or bends and there is a possibility of kinking, fit elbows into the hose.

Fan heads should be mounted as close to the area that requires heating as possible.

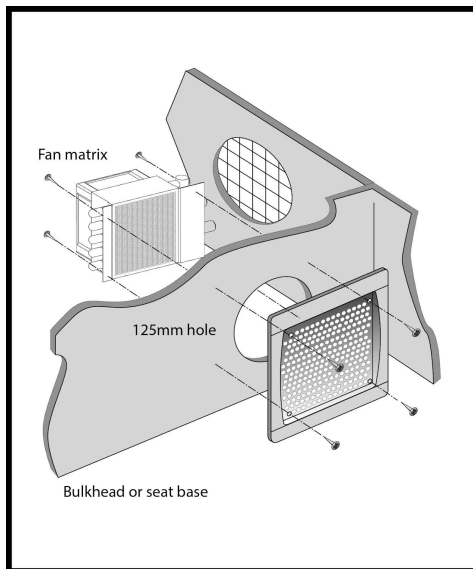

**Always make sure there is adequate return air ventilation to ensure the fan head works effectively.**

## Dieselheat Ducted Fan



Coolant flow direction is important for heater performance. Follow the coolant labels on the fan head and DH Hydronic system.

The ducted fan needs to be upright if installed using plumbing Case 2 (blocking ring out) or the system will struggle to pump air out of the heating coil.

## Kalori Fan Heads



With the Kalori fan head, coolant flow direction is not important. Coolant can circulate in either direction.

Kalori fan heaters can be mounted vertically or horizontally in all plumbing cases.

## Controlling The Air Temperature

It is recommended to always install either an automatic or manual valve inline with the fan head so that the coolant circulation can be closed off completely during hotter months. This stops the cabin fan heater from acting like a static radiator in a warm climate.

Temperature control can be achieved via 2 methods.



### **Method 1: Manual Fan Control**

All Kalori fans heads have 2 speed fans. These fans can be run on high or low speed, or switched off to manually control the temperature.

### **Method 2: Thermostat Control**

The Dieselheat touch screen thermostat is designed to control the room temperature and hydronic furnace.

The thermostat features 2 fan control outputs to control either a Kalori fan directly or the electronically controlled Dieselheat ducted fan units. In both cases, the thermostat gives the user 3 (adjustable) manual fan speeds and an automatic mode.

The thermostat also includes a relay that acts as a switch to turn a diesel hydronic furnace on or off and an output to control an electric ball valve to turn off the coolant when the fan is not in use.

The thermostat can operate in either hot water only or hot water and air heating modes.

This controller does not provide any error codes or diagnostics for diesel hydronic furnaces. This function must be provided by the manufacturer's controller.

## Tempering Valve - Controlling Water Temperature

When the system has been turned on and has warmed up, the water coming straight from the DH9 hot water service will be approximately 70-75 degrees.

The tempering valve not only controls the outlet temperature but will increase the usable hot water capacity. The volume of coolant at 70-75 degrees is directly related to how much hot water is available at 45-50 degrees.



The supplied tempering valves come pre-set at 50, but can be set at between 40 and 55 degrees by removing the yellow cap and rotating the brass bolt beneath it.

**The system will always be shipped with the tempering valve installed.**

**Never operate the system without the tempering valve or with a defective tempering valve as the outlet water temperature can be as hot as 80 degrees.**

## Watermark Approval

As per the note below, the DH9 uses a watermark approved plate heat exchanger and watermark approved fittings.



## Furnace Mounting (KIT)

When installing the furnace the following orientations are allowable.

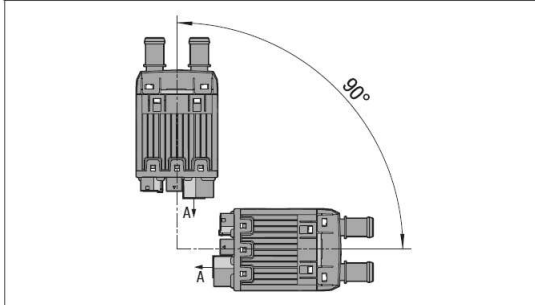

The furnace is mounted as follows:

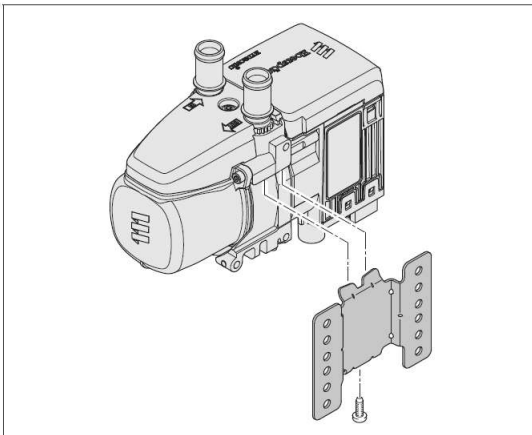
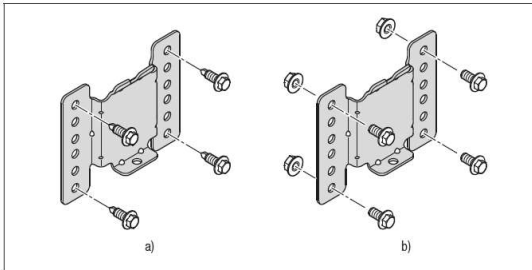

## Furnace Water Socket

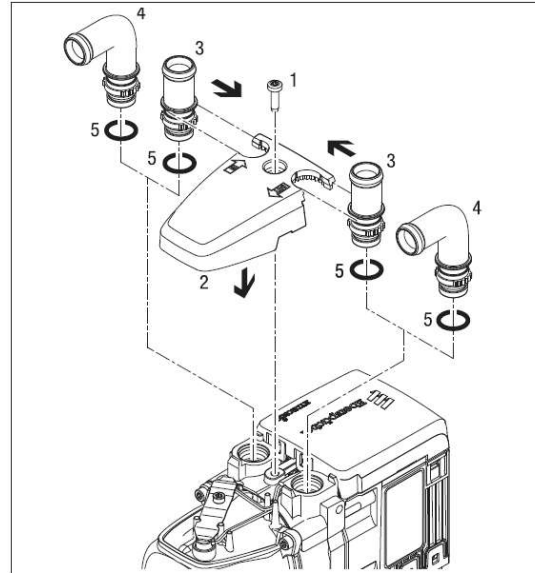

Picture 9

- |                               |                             |
|-------------------------------|-----------------------------|
| 1 Screw M5 x 18               | 4 Connection socket, angled |
| 2 Sensor cover                | 5 O-ring                    |
| 3 Connection socket, straight |                             |

## Coolant Pump Orientation (KIT)

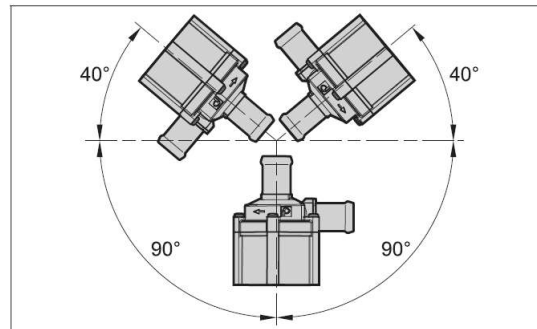

The coolant pump is not self priming, it must be at or below the base of the coolant tank



## Fuel System

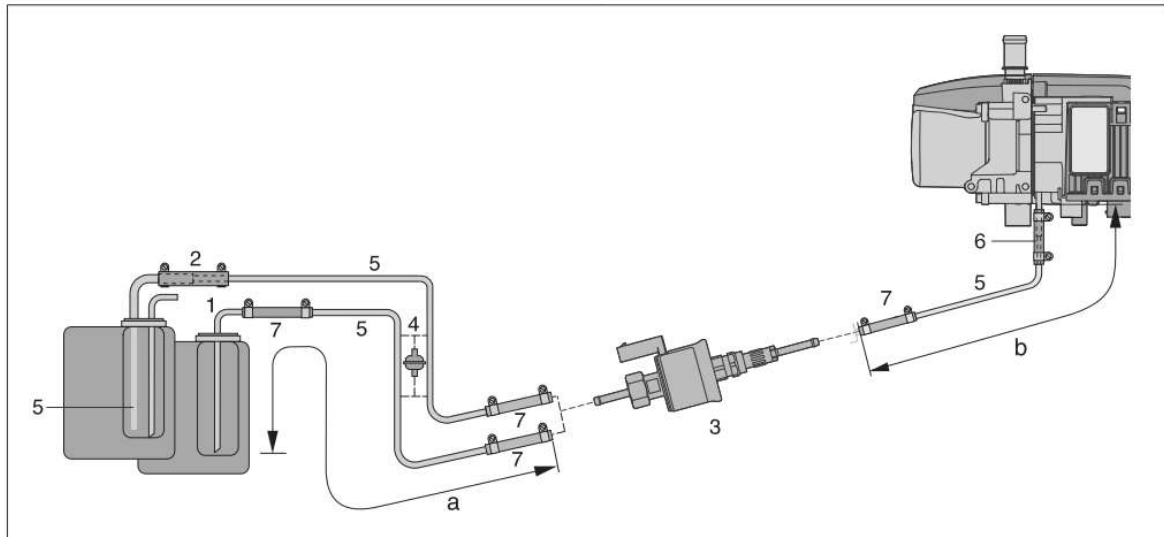

Picture 20

- |   |   |
|---|---|
| <p>1 Tank connection (di = Ø 2 mm, da = Ø 4 mm) – installed in the vehicle's own tank fitting</p> <p>2 Adapter (Ø 7.5 / 3.5 mm) – connected to the vehicle's own tank fitting, at a socket Ø 8 mm, used to pass through the intake line (fuel pipe 4 x 1) up to just before the bottom of the tank.</p> | <p>3 Metering pump</p> <p>4 Fuel filter – only required for contaminated fuel</p> <p>5 Fuel pipe, 4 x 1 (di Ø 2 mm)</p> <p>6 Adapter (Ø 4.5 / 3.5 mm)</p> <p>7 Fuel hose, 3.5 x 3 (di Ø 3.5 mm), approx. 50 mm long</p> |
|---|---|

Permissible line lengths: a = max 2m; b = max 6m

### Fuel System Installation

- To install the fuel line into the rubber joiners, use a small amount of vaseline or silicon grease prior to inserting into the joiner.
- When cutting the fuel line, use a sharp knife or snips. Do not allow the end of the line to compress or burr.
- If possible, install the fuel line running uphill from the pump to the furnace.
- Protect the fuel line with split corrugated conduit and secure it with cable ties or clamps to avoid mechanical damage or chafing.
- It is especially important to secure the fuel line in the vicinity of the fuel pump or impulses from the

pump can cause the fuel lines to rattle.

- When making fuel line connections, always push the fuel line all the way into the rubber joiner to ensure a butt joint and prevent bubbles forming.

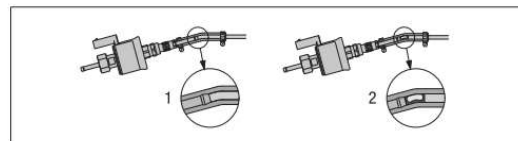

Picture 19

- |   |                                       |
|---|---------------------------------------|
| 1 | correctly laid lines                  |
| 2 | incorrectly laid lines – bubbles form |

- Ensure all connections have screw or single use ear clamps installed.
- Ensure the fuel line cannot contact anything hot like the furnace exhaust or a boat exhaust.

**Ensure the pump is installed with the correct orientation.** The outlet is on the opposite side to the power cable and the pump must be angled upwards at an angle of 15-35 degrees.

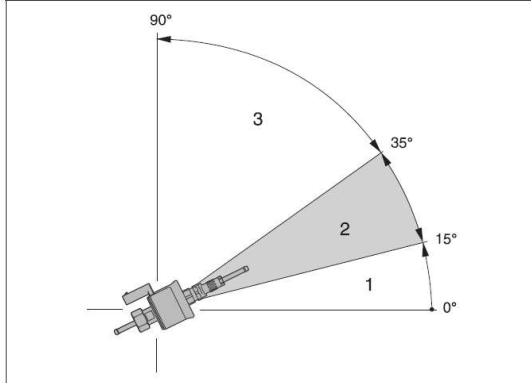

Picture 23

- 1 Installation position between 0° – 15° is not allowed
- 2 Preferred installation position within the range 15° – 35°
- 3 Installation position within the range 35° to 90° is allowed

It is advisable to install the pump as close as possible to the fuel source so it pushes the fuel instead of sucking it.

The Eberspacher fuel pump is very quiet so noise does not need to be a major consideration when selecting a location.

**Note: The pump contains a small filter behind the nut on the inlet side.**

**A small inline pre-filter is available as an option to prevent the fuel pump filter clogging if the fuel is dirty.**

### Fuel Source

The DH9 can be connected to an auxiliary fuel tank, to a day tank or to a connection point on the main fuel system or generator fuel system.

When connecting to main fuel systems in boats or motorhomes, it is important to ensure that the fuel take off point is not pressurised (downstream of any feed

pumps) and that there are no opportunities for air to enter the fuel lines.

### Allowable Suction Head

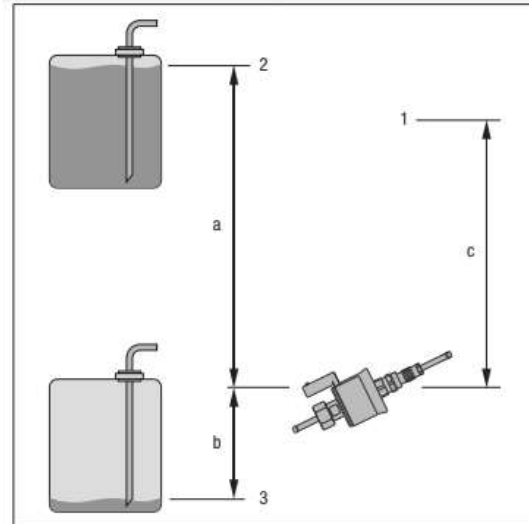

Picture 24

- 1 Connection at the heater
- 2 max. fuel level
- 3 min. fuel level

#### Pressure head from vehicle tank to metering pump:

a = max. 3000 mm

#### Suction head in pressure-less vehicle tank:

b = max. 500 mm for petrol

b = max. 1000 mm for diesel

#### Suction head in a vehicle tank in which negative pressure occurs during extraction (valve with 0.03 bar in the tank cap):

b = max. 150 mm for petrol

b = max. 400 mm for diesel

#### Pressure head from the metering pump to the heater:

c = max. 2000 mm

## Electrical Connection

All wires should be routed in split corrugated conduit and secured via cable ties or clamps to protect them from damage or chafing.

With the exception of the fuel pump cable, do not cut or shorten the loom. Spare cable should be bundled up neatly and tied out of the way.

Pay special attention to wires in the vicinity of the exhaust system and where they connect to the furnace to ensure they cannot be damaged by the hot exhaust.

The furnace is switched on and off via a simple switch, the Dieselheat thermostat or the EasyStart Pro controller. The wiring loom for the on/off switch can be extended if necessary.

The furnace requires 12V and uses approximately 8A to start. The operating current is approximately 2 - 4A once the starting sequence has completed. The furnace should be connected directly to the house batteries. Use 6mm<sup>2</sup> cable if extending the loom.

If connecting via an isolation switch or switchboard (not recommended), it is important that the switchboard has ample power supply from the batteries to prevent voltage drop making the unit hard to start. Small caravan-style fuse boxes are not recommended for this reason. Only commercial quality marine switchboards with DC bus bars should be used.

**Note: Except in an emergency, never switch the diesel furnace off at the main power supply. The furnace must go through a cool down sequence prior to stopping, which is triggered by switching the furnace off at its on/off switch or via the optional EasyStart Pro controller. For this reason, switches on the main power supply are not recommended.**

### Main Wiring

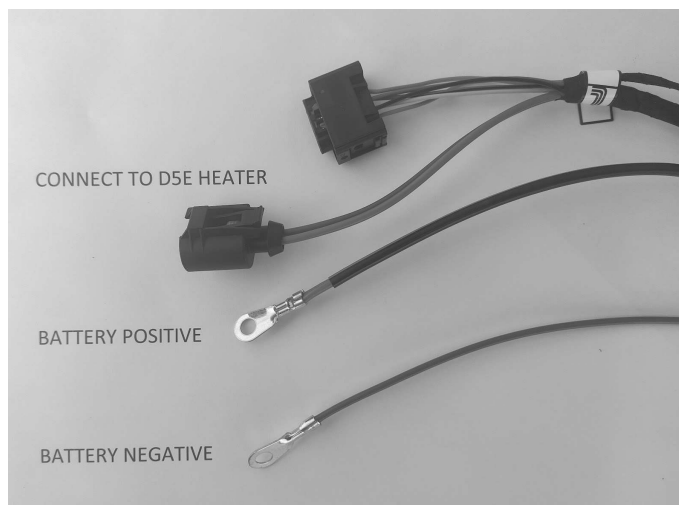

Connect the wires shown below from the loom directly to the battery and heater. Red with black sheath is positive, brown is negative. If you need to extend the power wires use 6mm<sup>2</sup> cable for the full run. The fuse box should be in close proximity to the battery.

### Fuel Pump

The fuel pump wires are not polarised. The cable bush has a small locking tab to lock the wires in place. Insert the fuel pump wires into the supplied cable plug. (Note that they can only be inserted one way. The side indicated by the arrow below faces the locking tab). Ensure the wires are all the way in (the green rubber should not protrude out the back of the plug). Ensure the plug clips are in place on the fuel pump.

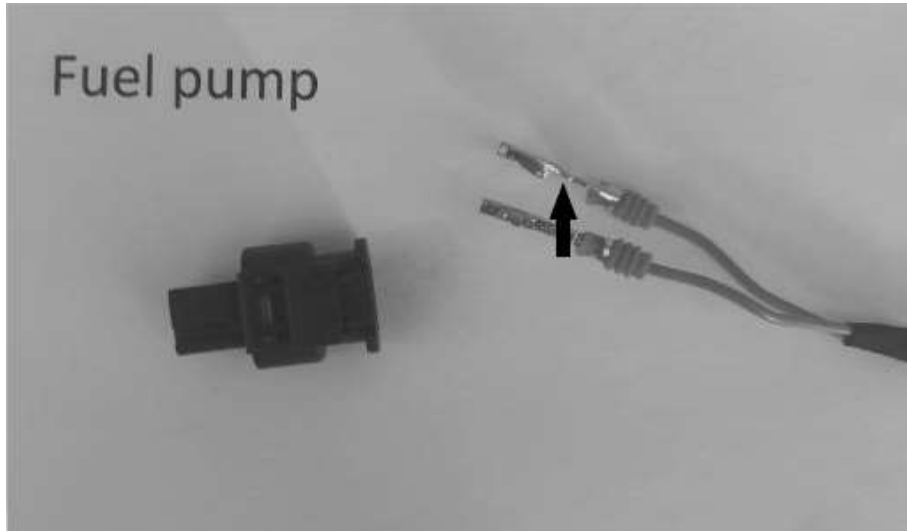

### Coolant Pump

Connect each end of the coolant pump cable to the heater and coolant pump. Note that on pre-assembled hot water systems the coolant pump wire will already be installed.

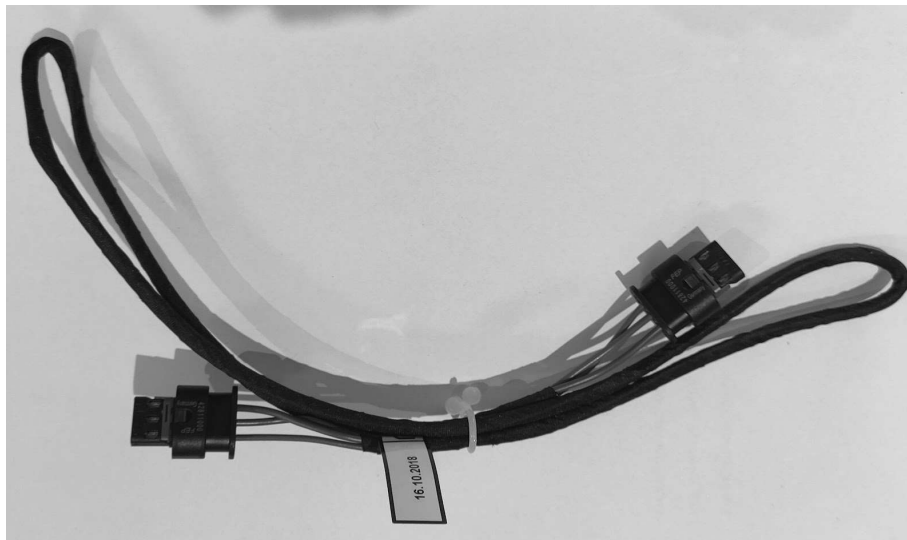

## Manual Control Wires

The furnace works with an ignition/activation wire (1). Applying 12V to this wire will signal the furnace to turn on. Removing the 12V signals the furnace to shut down. In simple systems, a switch between the red (2) and yellow (or sometimes blue) (1) wire will work to turn the system on or off.



1. Yellow or blue - Ignition/activation wire
2. Red - 12V activation power from 5A fuse
3. Brown - earth

## Pre-wired Packaged Systems

For Dieselheat pre-wired package systems, the Eberspacher loom has a 3 pin connector on the yellow (or blue), brown and red wires that connects to the Dieselheat thermostat loom. This supplies power to the thermostat, ducted fan and coolant valve as well as activating the Eberspacher furnace.

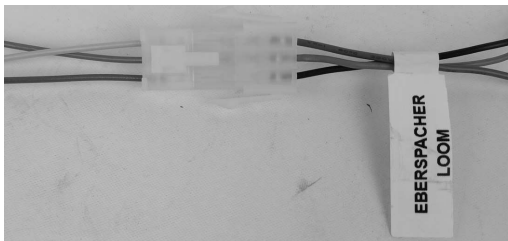

The loom also includes white/red and brown/black wires which are pre-taped off. These are not used.

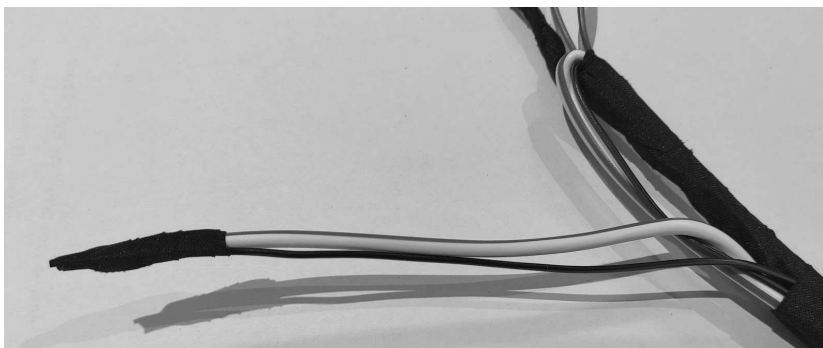

### EasyStart Pro Controller Connector - DO NOT HIDE THIS

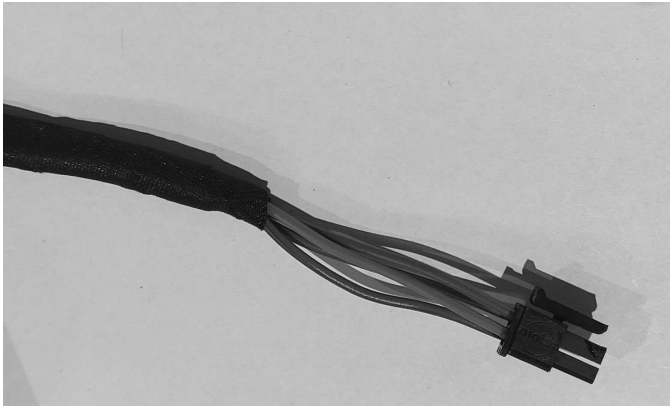

This is an optional controller.  
**This cable should not be cut or modified.**

Either plug this into the EasyStart Pro controller or bundle this cable and strap it in the vicinity of the DH9 in a position where it can be found and accessed if an EasyStart Pro controller is needed for diagnostic purposes in the future.

### Diagnostic Port

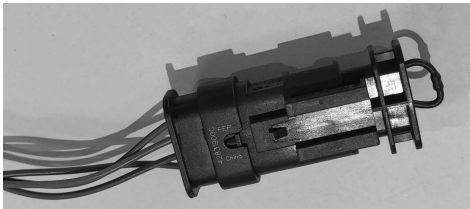

Diagnostic port with end cap. This must be left as is and should be installed in an accessible position next to the fuse box on the supplied mounting tab for future diagnostic purposes (see diagram below).

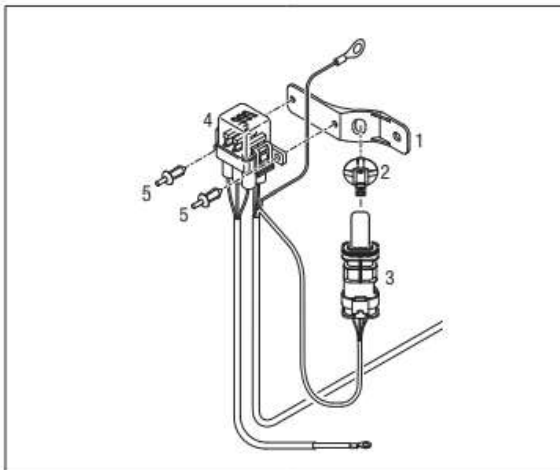

Picture 7

- |                         |                |
|-------------------------|----------------|
| 1 Combined bracket      | 4 Fuse bracket |
| 2 Retainer clip         | 5 Split rivet  |
| 3 Diagnostics connector |                |

## Main Wiring Diagram

- K1 - fan control relay
- A30 - fuse block, F1 heater control fuse, F2 control unit fuse, F3 fan relay fuse
- XS6/1 EasyScan (diagnostics port)
- XB8/1 fuel pump connector
- XB8/2 coolant pump connector
- XB6/4 EasyStart Pro connector

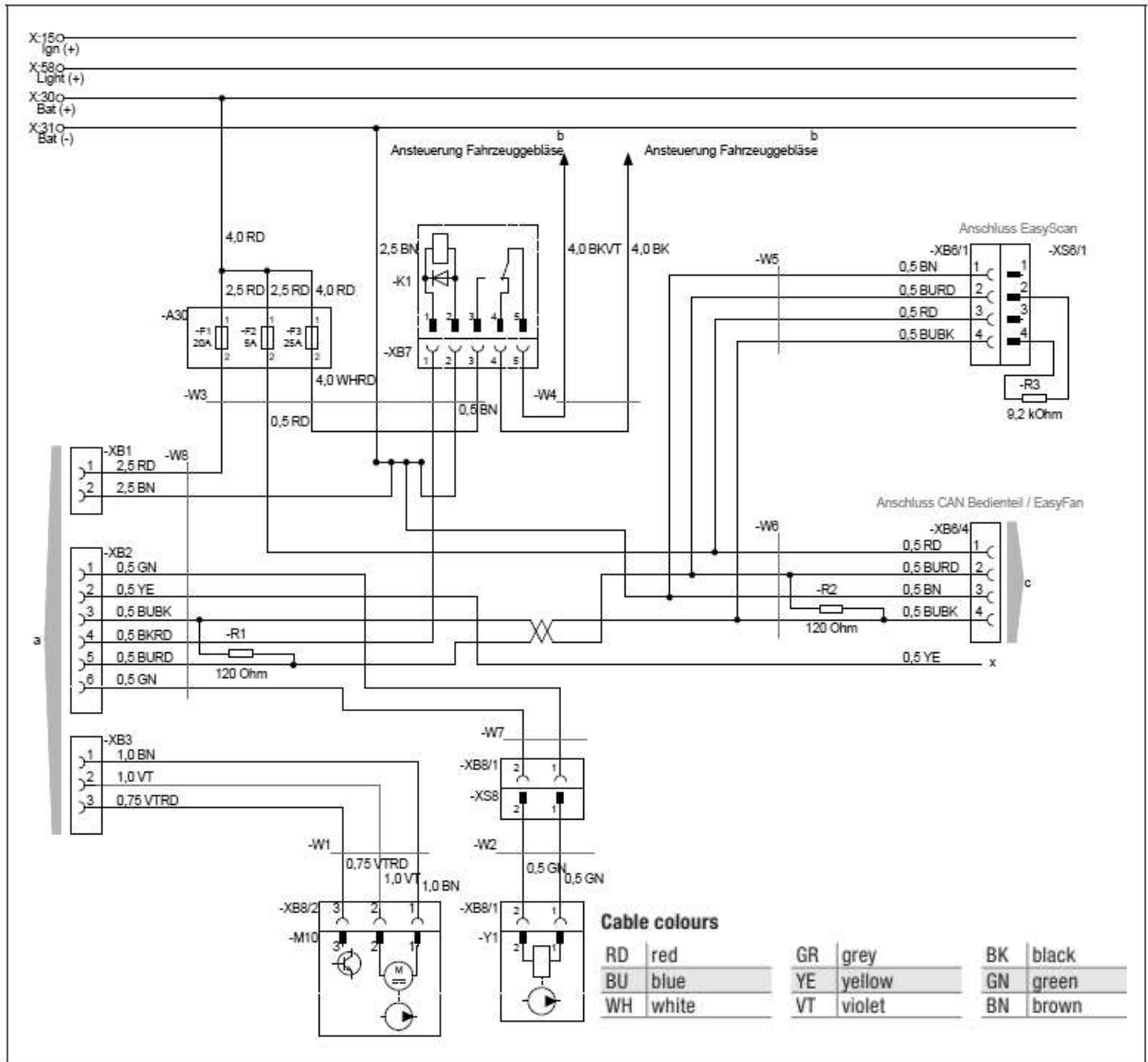

## Inlet and Exhaust General Arrangement

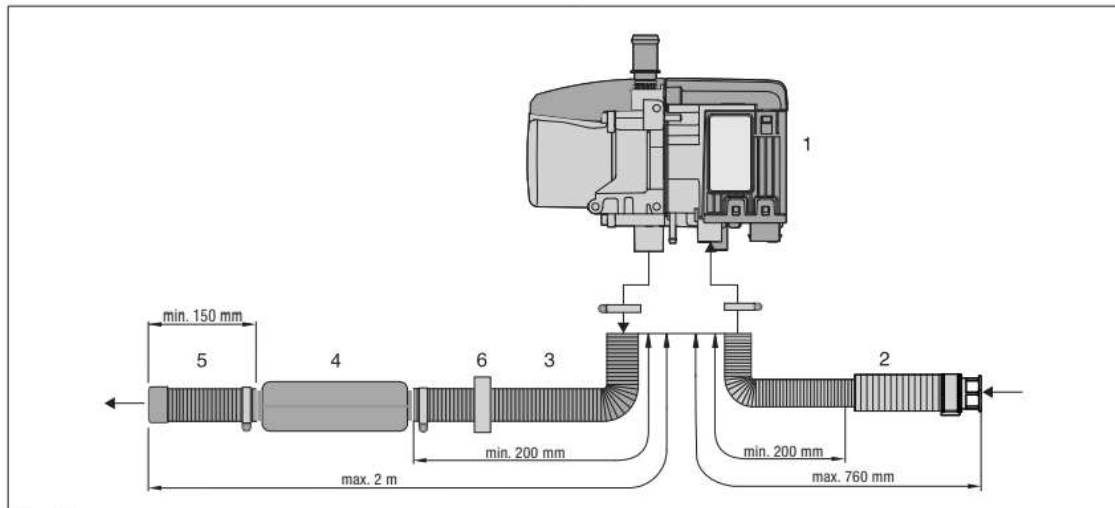

Picture 18

- |                                  |                                    |
|----------------------------------|------------------------------------|
| 1 Heater                         | 4 Exhaust silencer                 |
| 2 Combustion air intake silencer | 5 Exhaust pipe end with end sleeve |
| 3 Flexible exhaust pipe          | 6 Spacer ring                      |



## RV Exhaust

The exhaust system on an RV consists of 2 lengths of exhaust and a muffler. The exhaust should be installed in a manner that ensures it cannot dislodge or come into contact with any electrical wiring, water pipes, etc., as it is hot enough to melt plastics.

The exhaust should have a length of pipe before the muffler and generally at least 30cm of pipe after the muffler, as this helps to manage noise. If possible, install all of the exhaust pipe provided to reduce noise.

The exhaust pipe should be horizontal or have a slight downward slope to prevent condensation being trapped in the pipe.

**If the exhaust pipe has a valley or low spot, drill a 3mm hole at the lowest point to allow condensation to drain.**



If the exhaust is passing through a timber floor, we strongly recommend using the optional silicon plate, to make sure the exhaust cannot touch the timber, and to ensure there is a water/dust tight seal around the exhaust.



View of exhaust floor plate from below

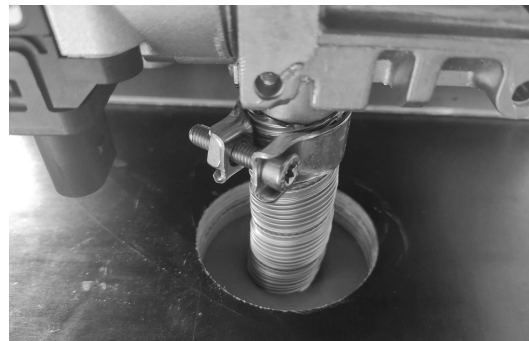

View of exhaust floor plate from above

The DH9 ASSEMBLED kit includes a floor drilling template, which makes it easy to correctly locate the exhaust floor hole.

## Marine Exhaust

**Always use high-quality marine stainless steel exhaust systems and clamps to ensure no exhaust gasses are vented inside the boat.**

The total maximum length of the marine exhaust is 2m. Always install the exhaust with a gooseneck on the inside of a hull fitting to prevent water washing back into the exhaust system.

**Note: The exhaust system reaches temperatures of up to 300°C. Always lag the exhaust and ensure that the exhaust is not in contact with any materials that could be damaged or set alight by this heat.**

### Installing the hull/deck fitting

The position of the exhaust hull fitting will depend on several factors, including where you have located the DH9, whether your vessel is a sailboat or a motorboat, and the suitable surfaces available.

On a sailboat, the preferred location is on the transom or cabin wall, as this is normally the area least likely to be affected by seawater when sailing. On a motorboat, the transom or side of the hull are suitable locations.

The hull fitting should be positioned as high as possible and a minimum of 300mm above the waterline to avoid water ingress.

If using a closable deck fitting, ensure it is located in a position where it cannot snare running rigging and where it is not a hazard for people walking on the deck.

To avoid potential safety issues, the exhaust system must be installed according to the following instructions:

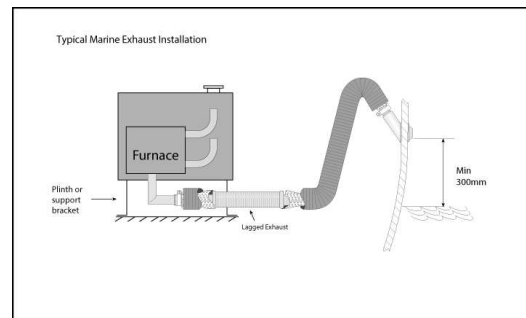

- Under no circumstances connect the heater exhaust to an engine exhaust or any other exhaust system.
- The exhaust outlet must vent directly to the atmosphere.
- Adequate clearance must be maintained around the exhaust system to prevent interference with important functional parts of the boat, such as steering or throttle cables.
- Route the flexible exhaust giving clearance and consideration to heat sensitive components such as fuel lines and electrical cables.
- Ensure the support brackets are used to secure the exhaust in order to avoid damage from vibration.
- Position the hull fitting so that other inlets (hatches, windows) cannot draw in exhaust fumes.
- Ensure the hull/deck fitting is positioned to allow fumes to exit freely so as not to affect nearby surfaces, such as fenders, ropes or mouldings.
- The exhaust must not be routed through the living area.

## Combustion Air

The DH9 KIT ships with the furnace combustion air inlet pipe and combustion silencer separated from the furnace. This is to enable the user to install the components in the most appropriate way.

For marine applications or instances in RVs where the furnace is installed inside a locker or cupboard, it is acceptable to install the combustion air inlet inside the engine room or locker.

The DH9 ASSEMBLED version ships with the air inlet pipe already installed and it draws air from the compartment in which it is installed.

For vehicles that will be operating in dusty conditions, it is not recommended to install the combustion air inlet outside the vehicle. If it is necessary to do this, use the following strategy:

- Keep the air inlet up high and behind some part of the vehicle like a crossmember or water tank.
- Make sure the exhaust points backwards and down.
- Consider covering the exhaust with an exhaust end cap when not in use in dusty conditions.



**Note: If the DH9 is installed in a sealed box or compartment, always ensure the box is opened before use. Operating**

**the furnace in a sealed box will result in inadequate combustion air, immediately causing the furnace to soot up.**

## Commissioning

It is a time consuming and messy operation to rectify any bad joints or leaks after the system is filled with coolant. The coolant system operates at approximately so check that all hose connections are secure and all hoses are kink free before filling the system with coolant.

When the system is 100% installed, insert the fuses in the power line and power up the furnace.

### Coolant Pump Priming

Remove the radiator cap on the DH9 hot water service. Fill the system with premixed coolant to approx 20mm from the top of the tank. The system will hold around 9L plus any additional coolant to fill fan heating heads and pipes.

If the system is overfilled, some overflow from the overflow spigot under the cap will occur on first startup. This is not an issue and will not continue once the coolant level has dropped.

With the cap removed, switch on the furnace and observe the coolant pump starting. It should give off a quiet whining sound. The system will normally prime immediately and air bubbles will appear in the top of the tank as air is pushed out of the internal pipes, fan heating head, etc. This only happens on first start up.

Check that the coolant level has not dropped excessively and top up if necessary.

Observe the coolant in the tank through the filler and you should see some swirling and turbulence. The pump should be whining softly, not loudly. This indicates

the pump is primed and coolant is circulating and it is safe to allow the furnace to start.

### Extended Air Bleeding/Priming

If the coolant is not circulating in the system as noted above, follow this procedure:

Recheck that all the plumbing is correctly installed and turn on all fan head valves.

Turn the unit on. The coolant pump will start. It will often surge as it tries to prime. Wait until the fuel pump starts to tick, then turn the unit off before the furnace tries to start.

Wait for the unit to turn off completely, then repeat.

You may need to repeat the above steps 4 or 5 times to push all of the air out of the system. Look at the top of the tank and you will see small air bubbles coming through the liquid.

The pump will change tone and you will see the coolant swirling on the surface once priming has been achieved.

### Initial Startup

Once the coolant pump is primed, leave the switch on and the furnace will attempt to start.

The furnace will not start until the fuel pump and fuel line have primed.

A furnace start process involves 2 separate start attempts and takes approx. 6 minutes. During each start attempt, the coolant pump runs, the combustion fan revs up and down and the fuel pump attempts to pump fuel.

At the end of a start process (after 2 attempts), the furnace will shut down and wait. A new start process can be triggered by turning the furnace off and on again.

**Note: The furnace will lock out after approx. 10 failed start processes. Always double check the fuel line, pump orientation and fuel source before commencing startup. An EasyStart Pro controller is required to unlock a locked out furnace.**

### Post Initial Startup

As the furnace begins to heat the coolant, all the hoses will start to get warm. Move your hands over all the hoses to check they are all of a similar temperature.

After a few minutes, the DH9 water heater should be warm to the touch. The hoses to and from the cabin fan heater should be a similar temperature to the main hoses.

If these hoses are still at ambient temperature, it is likely that there is an air lock in the loop or the pump is not primed properly. Check the shut off valves or the system design to determine why the coolant isn't circulating properly.

If everything is getting warm, top the coolant level up in the DH9 hot water service until it is approximately 20mm from the top of the tank and replace the filler cap. Allow the system to fully heat for 15 minutes. Recheck the whole system for leaks.

Depending on the ambient temperature, the furnace will cycle down after about 8 minutes as the coolant reaches 70°C. All hoses should be at a similar temperature and, if installed, the fan head should blow hot air.

If water has been used for commissioning/testing, drain the system down and replace the water with coolant.

Congratulations! You have now successfully commissioned your DH9 system.

### Coolant Furnace Operation

- Turn on the furnace with the on/off switch.
- After approximately 3 seconds, the coolant circulating pump will come on. The glow pin and fuel pump will then come on and the furnace will start its combustion cycle.
- Once the furnace obtains full combustion, it will continue to produce heat on full power until the coolant temperature reaches 70°C. This will take approximately 8 minutes, depending on the ambient temperature.
- At this temperature, the furnace will cycle down to its lower heat setting, but the circulating pump will continue to circulate coolant around the system.
- When the coolant reaches approximately 80-85°C the furnace will shut down, but the coolant circulation pump will continue.
- The furnace will not restart until the coolant temperature drops to approximately 68°C. This will happen either by heat dissipation over time, or if the DH9 hot water service or cabin fan heater demands heat.

**Note: Only turn the furnace off at its own switch. Do not cut power to the furnace during any stage of its operation.**

## Commissioning Troubleshooting

Problem	Things to Check
On initial switch on, furnace does nothing.	<ul style="list-style-type: none"> <li>• Check fuel pump connection wires are properly inserted into connector and connector is properly plugged into the pump.</li> <li>• Check coolant pump wires are properly connected.</li> <li>• Check power supply and fuses.</li> <li>• Check furnace is wired directly to batteries.</li> <li>• Check power wiring polarity - red (inside black sleeve) is positive, brown is negative.</li> </ul>
Furnace tries to start but doesn't start.	<ul style="list-style-type: none"> <li>• Check fuel pump is orientated correctly.</li> <li>• Check fuel flow in fuel line by shining a torch on the fuel line and looking for bubbles or advancing fuel front.</li> <li>• If installed, check the fuel filter has filled with fuel.</li> <li>• The fuel pump will tick more loudly until filled with fuel. Check fuel pump noise when pump is pumping.</li> <li>• Check all fuel line connectors are tight and air cannot enter the fuel line.</li> <li>• Check battery voltage is above 12.5V.</li> <li>• Check furnace is wired directly to batteries as per install instructions.</li> </ul>
Eberspacher Only: furnace has tried to start multiple times and is now 'dead'.	<ul style="list-style-type: none"> <li>• The furnace has locked out due to excessive start attempts and will need to be unlocked using an EasyStart Pro controller.</li> </ul>
Furnace starts and runs for approx. 1 minute, then shuts down very quickly.	<ul style="list-style-type: none"> <li>• Check coolant circulation.</li> </ul>
System works but the air heating fan head is not hot.	<ul style="list-style-type: none"> <li>• Check all shutoff valves.</li> <li>• Review plumbing and use of bypass valves as per the suggested system schematics.</li> <li>• On larger systems (boats), review the use of booster pumps.</li> </ul>
System runs but there is no hot water.	<ul style="list-style-type: none"> <li>• Check the system plumbing and ensure that hot coolant is passing through the plate heat exchanger (remote-mounted furnaces only).</li> <li>• Check the thermostatic tempering valve is installed with the 'H' at the top and the 'C' at the bottom.</li> </ul>
System heats up but fan heads do not get hot.	<ul style="list-style-type: none"> <li>• Check fan head shutoff valves are open.</li> <li>• If using a valved bypass valve, ensure the bypass valve is partially closed.</li> <li>• If using a valveless bypass valve, check the bypass valve is on the same level as the fan head.</li> <li>• Check tank plumbing and bypass arrangements are in accordance with diagrams in these instructions.</li> </ul>
Fan heads get hot but do not blow hot air.	<ul style="list-style-type: none"> <li>• Check fans are wired with correct polarity.</li> <li>• Check fan head has adequate return air as per instructions.</li> </ul>

## TWO YEAR PRODUCT WARRANTY

Dieselheat offers a 2 year warranty on this product. Upon receipt of proof of purchase of a product, Dieselheat will, where possible, provide product support via telephone or email. If Dieselheat determines that the issue necessitates the return of the product for inspection and/or repair, it is your responsibility to uninstall the product and return the product at your cost to Dieselheat. Upon repair of the product, Dieselheat will return the product to you at no cost. It is your responsibility to reinstall the product. See our full warranty terms on our website.